

01 - 2001 S. AG.

2 - Hood/Tank

CODE	DESCRIPTION
150819	CABLE HOLDER PG16 WITH HOLE
160716	PLUG , 22
160805	GASKET D.8
160907	CONNECTION FOR TABLES C95-155
161179	BACK COVER C166
180624	DOOR GUIDE C95-155-C165
200497	GASKET FOR DOOR GUIDE C85-C140
260115	STAIN.ST.TE SCREW 8X20 A2 UNI
260116	SCREW TE 8X35
260139	SCREW TE 5X16
260219	STAINL.ST TCP SCREW 6X35 A2 UN
260223	M5X12 MSH/HD SCREW SPECIAL S/S
260224	TB-SCREW 6X15 B23-10-11-12
260312	SCREW TSP 4X16
260404	STAINLESS STEEL NUTS D6 UNI 55
260406	NUT 8MA
260415	STAINLESS STEEL SELF-LOCKING N
260418	SELF-LOCKING NUT M4
260502	S/S FLAT WASHER D.4
260505	STAINL.STEEL FLAT WASHER D8
260511	GROWER WASHER D.5
260512	ST/ST GROWER WASHER D6
260513	GROWER WASHER D8
260530	STAINL.ST WASHER 7X22X2
260538	WASHER 18X6X1,5 ST/ST
290701	HEXAGON BLIND NUTS GM H12
310212	BLIND NUT M6 BLACK NYLON
321928	PLATE F.GUIDE C140
322117	RACK GUIDE C95-C155
322290	LEVER FOR HANDLE C166
331046	HANDLE C166
331208	ST.STEEL FOOT
331835	BRACKET F.MAGNET C165
341144	FRAME
341597	INSULATED HOOD FOR C166
350387	SCHIENALE C 166
351310	LEFT PANEL C95-C155
351314	RIGHT PANEL C95-C155
351324	BACK PANEL
390173	BACK PANEL C166
390178	BACK PANEL
411002	PERMANENT MAGNET 24X12

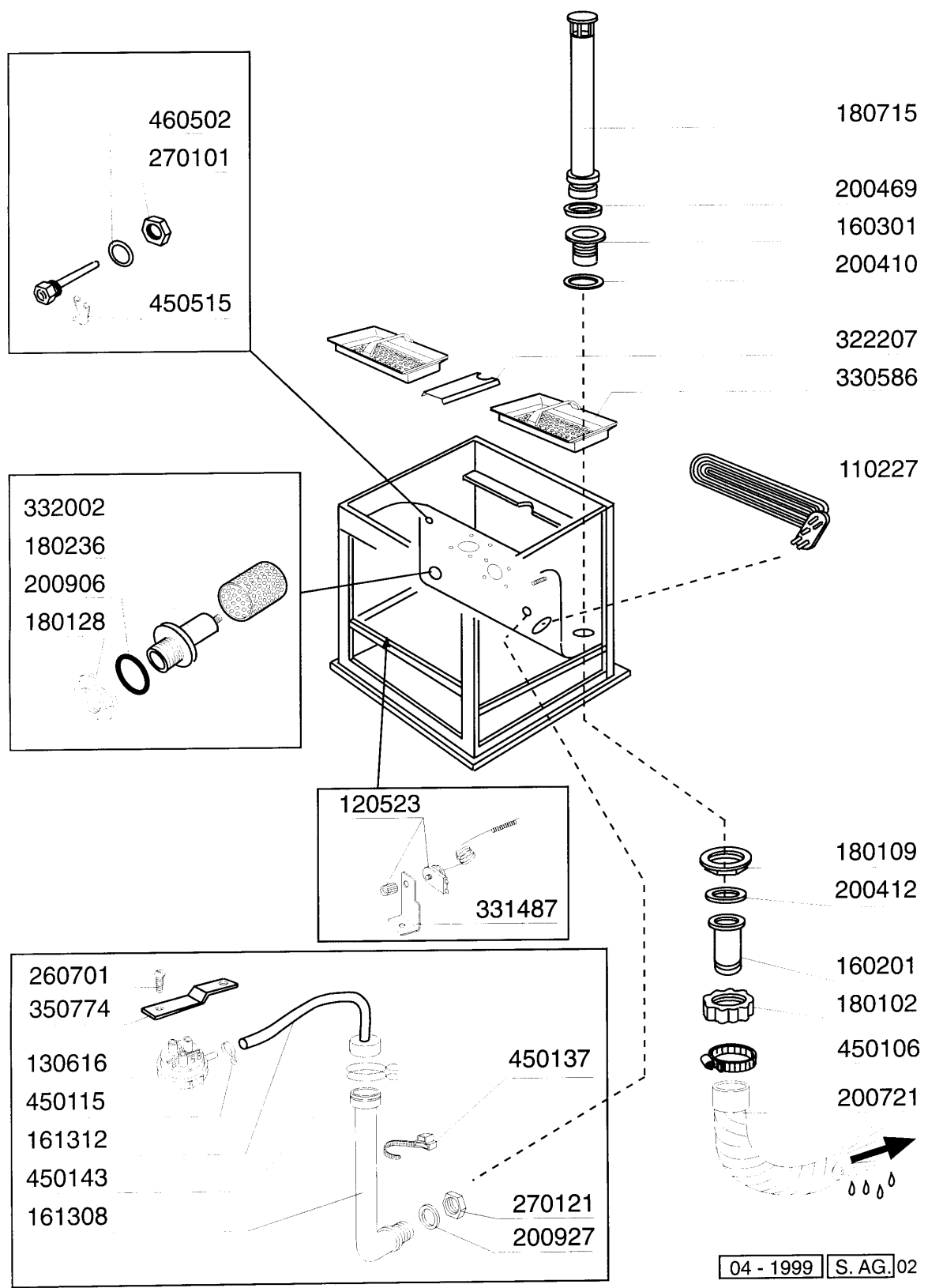

**3 - Tank**

<b>CODE</b>	<b>DESCRIPTION</b>
110227	HEAT. ELEMENT 3000W 230/400V
120523	SAFETY THERMOSTAT 110Ø
130616	PRESSURE SWITCH 190/80 FOR C95
160201	ELBOW F.TANK INLET MOPLN
160301	DRAIN OUTLET 1"1/2 C-S-N
161308	AIR CHAMBER C95-155
161312	HOSE FOR PRESSURE SWITCH C95-1
180102	DRAIN PIPE NUT 1"1/2 F45-55
180109	LOCK NUT 1 1/2"
180128	RING NUT 65,4 C140 C85
180236	PUMP SUCTION FOR AC-ACR-C155
180715	OVERFLOW PIPE C95-C155-C165
200410	DRAIN OUTL.WASH.1 1/2"65X47X2
200412	GASKET DRAIN 11/2" 45X33X3
200469	STAND PIPE O RING 45X35,5X7
200721	DRAIN HOSE 28X35 2MT.
200906	GASKET D.92X66X2
200927	GASKET FOR AIR TRAP
260701	SCREW 3,5X9,5
270101	HEXAGON LOCK NUT 1/2"
270121	NUT FOR AIR TRAP
322207	CENTRAL SUPPORT FOR FILTERS C1
330586	TANK FILTER C95-C155-C165
331487	BRACKET FOR 1 THERMOSTAT
332002	ROUND SUCTION FILTER FOR C95-1
350774	BRACKET
450106	CLAMP FE ZN 32-44 H=12,2
450115	ELASTIC CLAMP D.8,3/7,8
450137	COLLAR CONNECTION WITH BASE 31
450143	CLAMP D.39,7 X 37,7
450515	STAINL.ST.SHIELD FOR 1 THERMOS
460502	GASKET 30X21X2

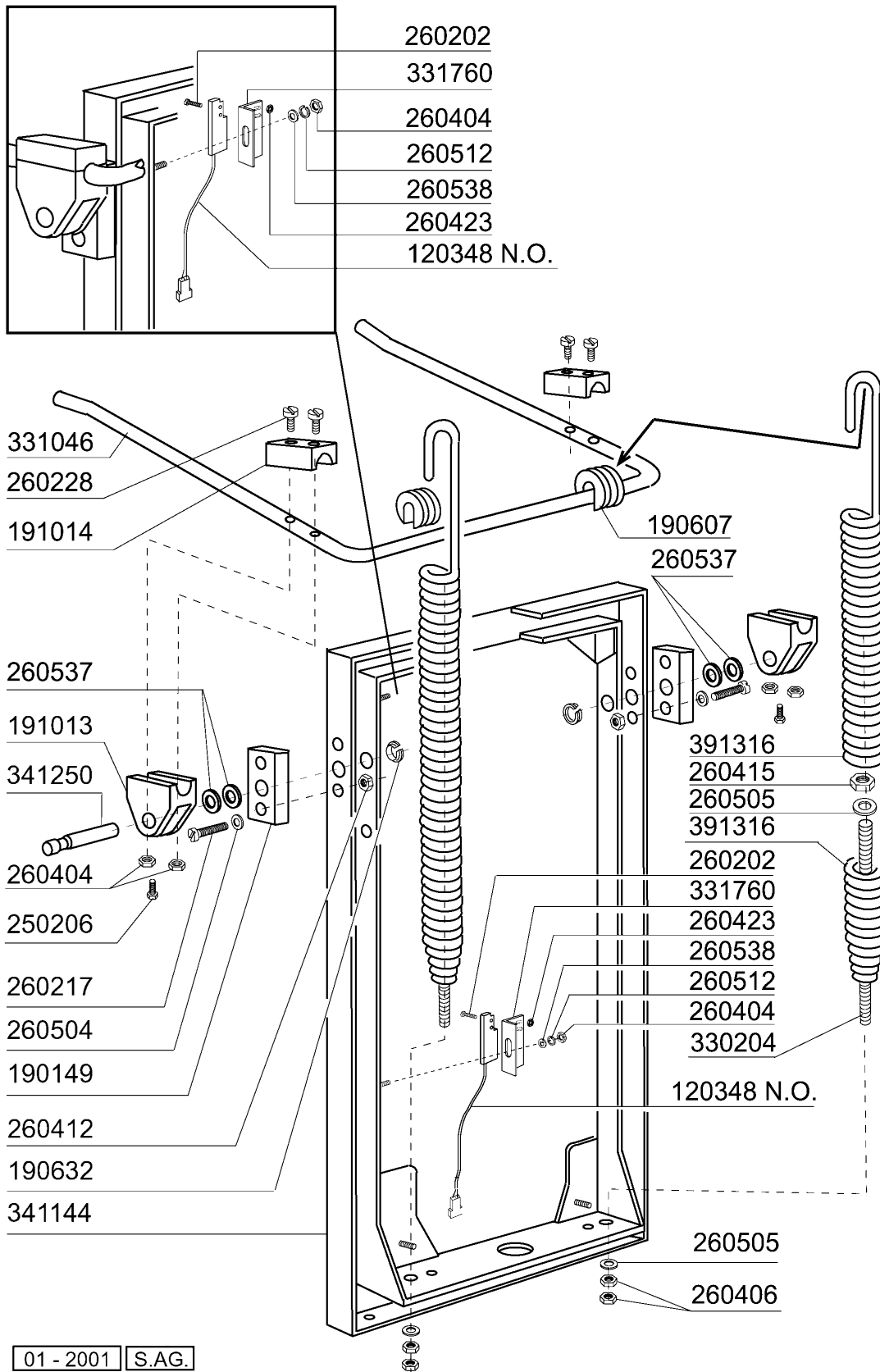

01 - 2001 | S.A.G.

4 - Handle

CODE	DESCRIPTION
120348	MAGN.SWITCH (N.O.)
190149	REINFORCEMENT FOR HANDLE SUPP.
190607	HANDLE BUSH C30-70
190632	"NYLINER" BUSH
191013	HINGE F. SUPPORT C30-C70
191014	FLANGE F. HANDLE C30-70
250206	GRUB SCREW D.6
260202	SCREW TCP 3X16
260217	SCREW TCP 6X25
260228	STAINL.ST SPECIAL SCREW 6X42 3
260404	STAINLESS STEEL NUTS D6 UNI 55
260406	NUT 8MA
260412	SELF-LOCKING NUT M6
260415	STAINLESS STEEL SELF-LOCKING N
260423	SELF-LOCKING NUT M3
260504	ST/ST FLAT WASHER D6
260505	STAINL.STEEL FLAT WASHER D8
260512	ST/ST GROWER WASHER D6
260537	STAINL.STEEL FLAT WASHER D13X2
260538	WASHER 18X6X1,5 ST/ST
330204	SPRING HOOK C95/155-LC380
331046	HANDLE C166
331760	BRACKET
341144	FRAME
341250	HANDLE PIN C85 C140
391316	SPRING FOR HANDLE C85/140-G75

5 - Hood lifting device

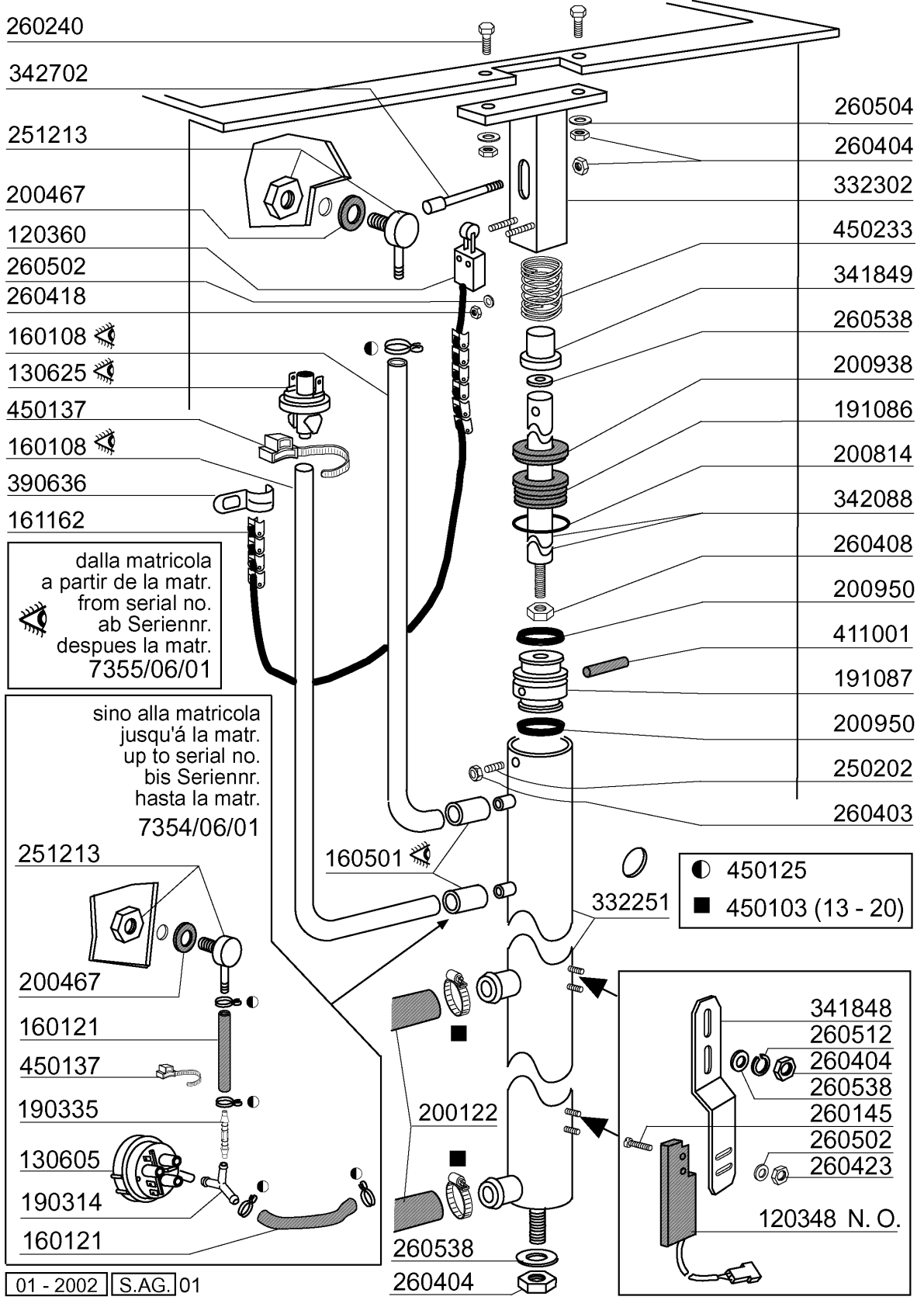

260240

342702

251213

200467

120360

260502

260418

160108

130625

450137

160108

390636

161162

dalla matricola  
a partir de la matr.  
from serial no.  
ab Seriennr.  
despues la matr.  
7355/06/01

sino alla matricola  
jusqu'à la matr.  
up to serial no.  
bis Seriennr.  
hasta la matr.  
7354/06/01

251213

200467

160121

450137

190335

130605

190314

160121

01 - 2002 | S.A.G. | 01

260504

260404

332302

450233

341849

260538

200938

191086

200814

342088

260408

200950

411001

191087

200950

250202

260403

160501

332251

450125  
 450103 (13 - 20)

200122

260538

260404

341848  
260512  
260404  
260538  
260145  
260502  
260423  
120348 N. O.

## 5 - Hood lifting device

CODE	DESCRIPTION
120348	MAGN.SWITCH (N.O.)
120360	SECURITY MAGN.SWITCH
130605	PRESSURE SWITCH 50-30 1 LEVEL
130625	PRESSURE SWITCH
160108	INJECT.INLET HOSE D.8X5
160121	HOSE EPDM D. 5 X 9
160501	SPACER FLIGHT D.9X25 CONVEYOR
161162	CHAIN F.PROTECTION CABLE ATTRE
190314	Y-NIPPLE OF PRESS.SWITCH N 2S
190335	CONNECTION
191086	TESTATA X CANOTTO-C166-
191087	PISTON
200122	HOSE 11X19
200467	DUTRAL GASKET F. AIR TRAP
200814	O-RING 34,52X41,58X3,53
200938	GASKET
200950	VITON GASKET
250202	STAINL.ST GRUB 5X8 UNI 5927
251213	INJECTIOR S/S FOR DETERGENT IN
260145	SCREW TE 3X16
260240	SCREW
260403	NUTS D.5
260404	STAINLESS STEEL NUTS D6 UNI 55
260408	S/S NUTS D.12
260418	SELF-LOCKING NUT M4
260423	SELF-LOCKING NUT M3
260502	S/S FLAT WASHER D.4
260504	ST/ST FLAT WASHER D6
260512	ST/ST GROWER WASHER D6
260538	WASHER 18X6X1,5 ST/ST
332251	CYLINDER FOR C166-2
332302	ATTACCO CILINDRO X CAPOT C166
341848	SUPPORT
341849	SUPPORT
342088	SHAFT
342702	SHAFT
390636	BRACKET
411001	PERMANENT MAGNET 8X40
450103	CLAMP FE ZN. 13-20 H=9
450125	ELASTIC CLAMP D. 10,4X9,8
450137	COLLAR CONNECTION WITH BASE 31
450233	SPRING



- 450103 (13 - 20)
- ◆ 450107 (38 - 50)
- ★ 450119 (58 - 75)
- ◼ 450127 (68 - 85)

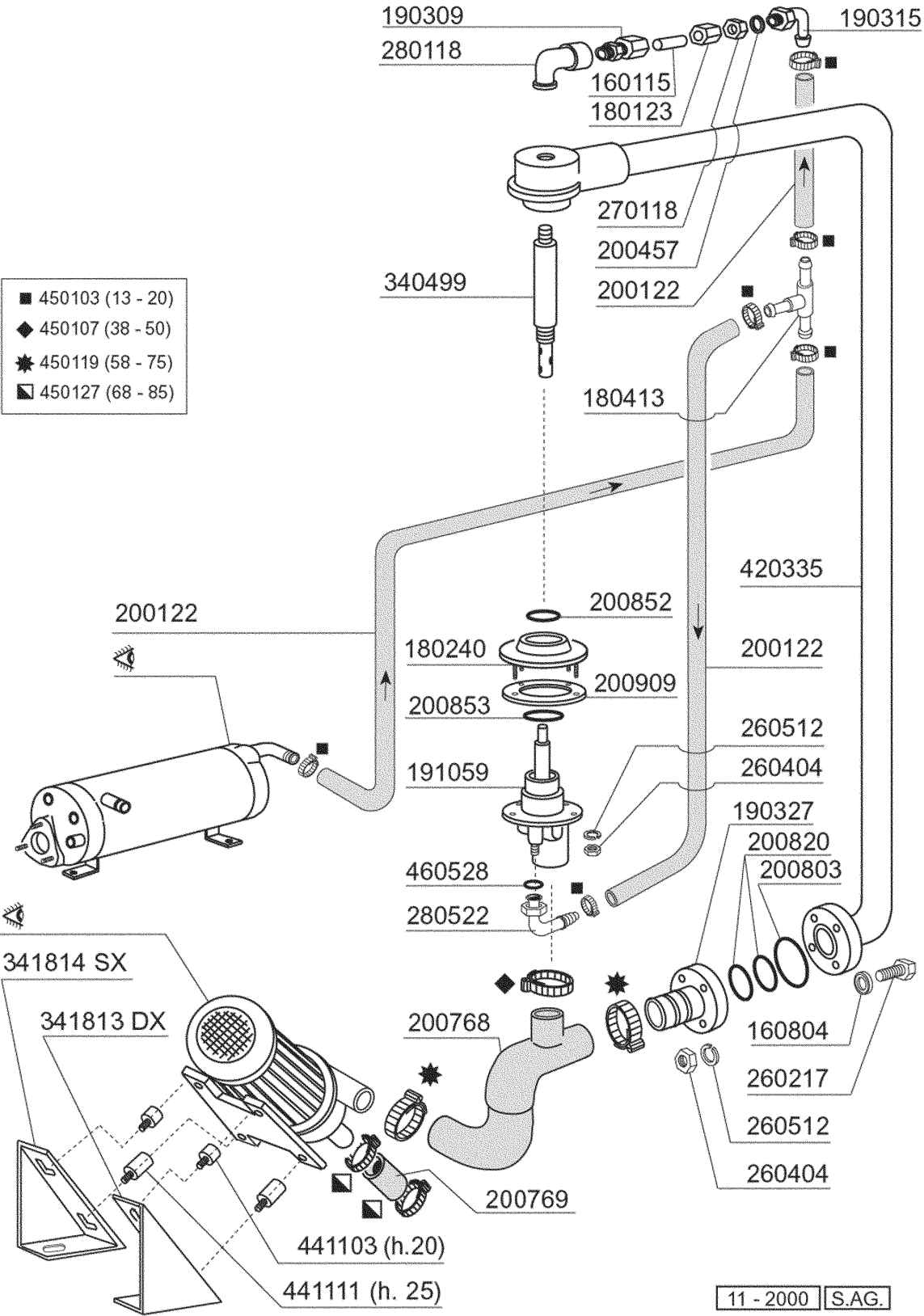

11 - 2000 | S.AG.

6 - Wash/Rinse column

CODE	DESCRIPTION
160115	PL.TUBE.D.9.5 B41 (3/8) C30-
160804	GASKET D.6
180123	CONNECTION NUT / RINSE 5/8 C30
180240	FLANGE FOR PIPE ASSY. C95-C155
180413	TEE NIPPLE D.11,5 - RINSE ASSE
190309	CONNECTION STRAIGHT 3/8"B41C30
190315	ELL RINSE C30-70
190327	INLET FLANGE C95-C155-C165
191059	LOWER WASH ARM SUPPORT C95-155
200122	HOSE 11X19
200457	GASKET D.24X16X3 NEOPRENE
200768	DELIVERY HOSE "3 WAYS" C95-C15
200769	OUTLET HOSE C95-C155-C165
200803	OR GASKET 3,53X98,02X105,08
200820	O-RING151 46,99X5,33X57,6
200852	O-RING D.58,42X63,66X2,62
200853	O-RING D.63,5X70,56X3,53
200909	GASKET F.LOWER WASH ARM SUPP.C
260217	SCREW TCP 6X25
260404	STAINLESS STEEL NUTS D6 UNI 55
260512	ST/ST GROWER WASHER D6
270118	NUTS FOR ELBOW 5/8 C30-70
280118	ELL FF 3/8" - 1/4" C140-155
280522	NIPPLE FOR RINSE HOSE C95-C155
340499	SPINDLE CENTR. CROSS C34
341813	PUMP SUPPORT C95/155/165
341814	PUMP SUPPORT C95/155/165
420335	WASH COLUMN C95-C155-C165
441103	PUMP FEET
441111	PUMP FEET 25X25XM6
450103	CLAMP FE ZN. 13-20 H=9
450107	CLAMP FE ZN 38-50 H=12,2
450119	CLAMP FE ZN. 58-75 H=12,2
450127	CLAMP FE ZN. 68-85 H=12,2
460528	GASKET 15X10X2 FOR RINSE NIPPE

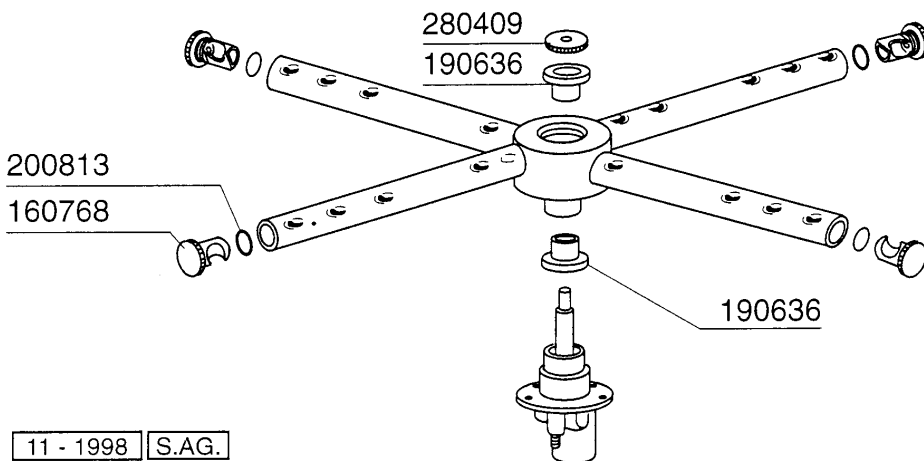
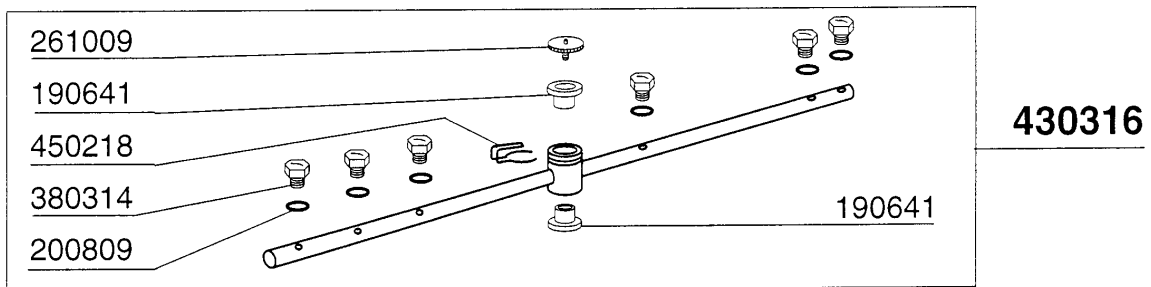
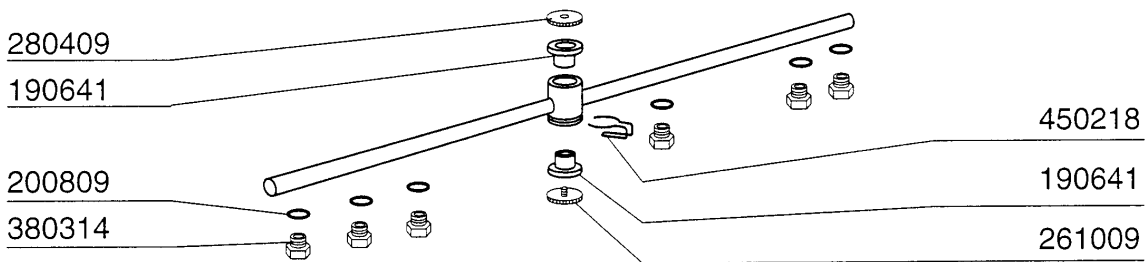
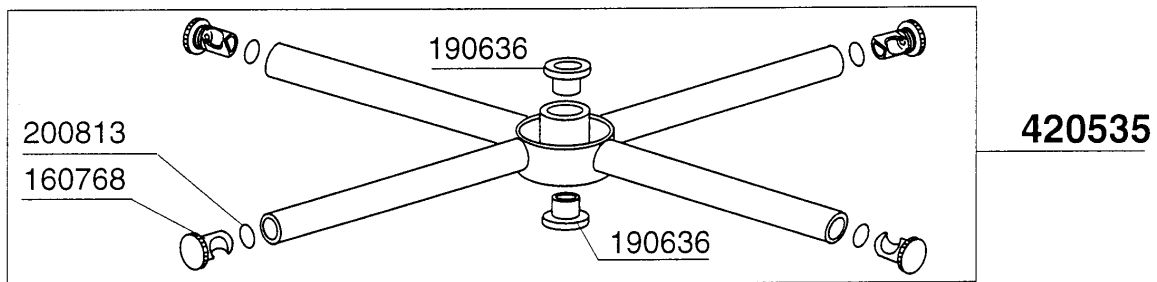
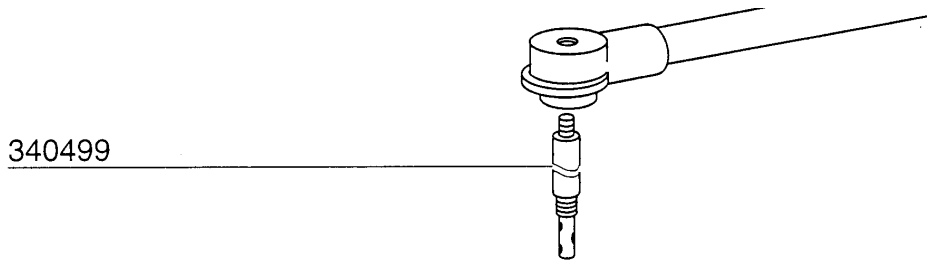

11 - 1998 S.A.G.

7 - Wash arm

CODE	DESCRIPTION
160768	PLUG FOR "C95-155" WASH ARM
190636	BUSH FOR C95-155-165 WASH ARM
190641	BUSH FOR C95-155-165 RINSE ARM
200809	OR GASKET 1,78X8,73X12,29
200813	OR GASKET 2,21X16,36X20,78
261009	RETAIN.SCREW FOR WASH-RINSE AR
280409	RETAIN.LOCK NUT CENTR.CROSS C1
340499	SPINDLE CENTR. CROSS C34
380314	RINSE JETS 801/HR
420535	WASH ARM C1300-C155
430316	RINSE ARM FOR C95-C155-C165
450218	SPRING F.RINSE ARM RETAIN.SCRE

8 - Hydraulic assembly

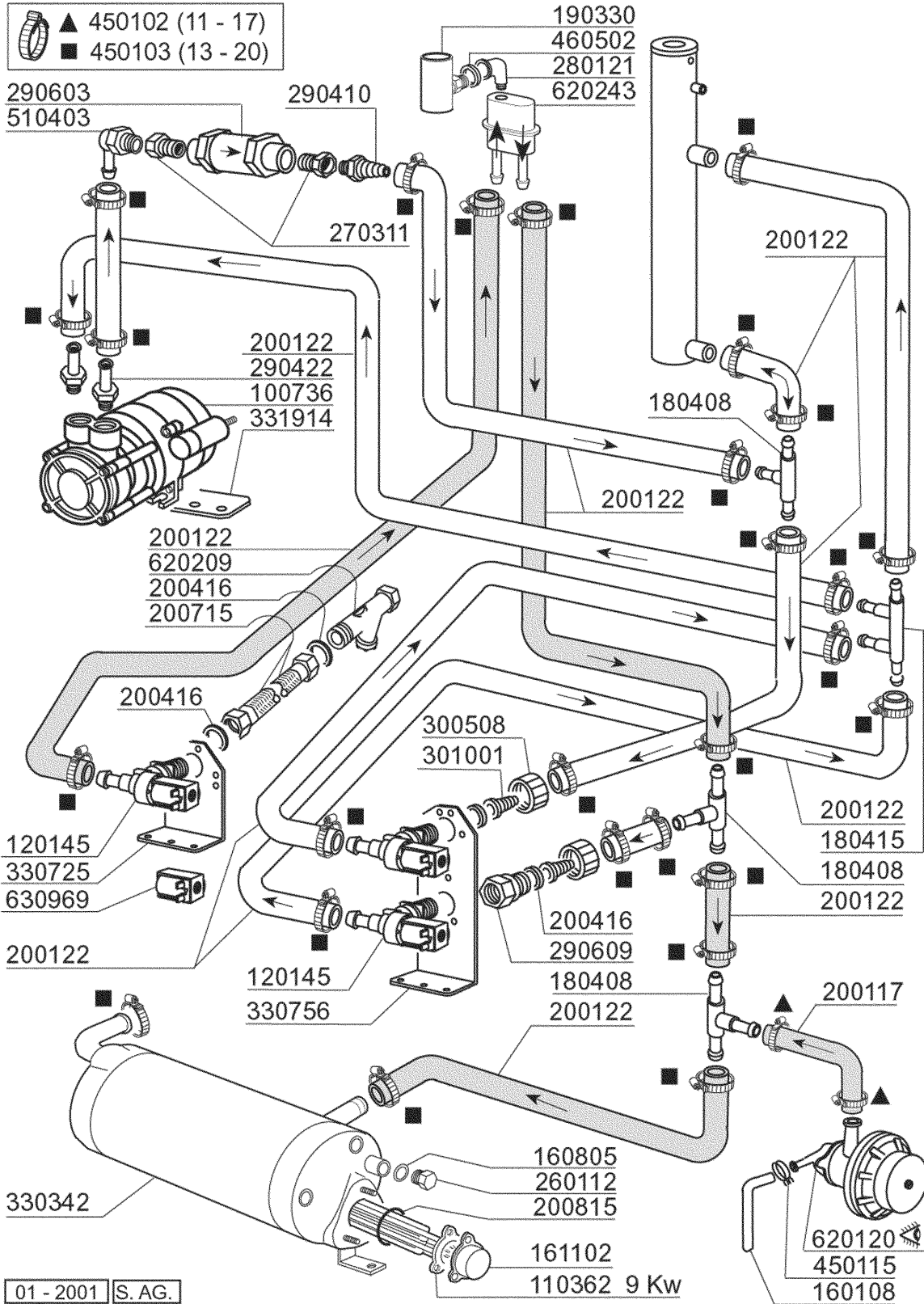

01 - 2001 S.A.G.

## 8 - Hydraulic assembly

CODE	DESCRIPTION
100736	PUMP HP 0,5 220/240-50HZ
110362	HEAT.ELEMENT 9000W 220/380V
120145	SOLENOID VALVE 12 LT 1 WAY
160108	INJECT.INLET HOSE D.8X5
160805	GASKET D.8
161102	ELEMENT COVER MOPL.
180408	TEE-NIPPLE F.INJECT.W/CENTR.RE
180415	TEE NIPPLE DOUBLE "T"
190330	TEE FOR VAACUM BREAKER
200117	RUBBER HOSE 7X16
200122	HOSE 11X19
200416	GASKET D. 3/4"
200715	HOSE WATER INLET 2M STAINL.ST
200815	O-RING F. HEAT.ELEM.
260112	STAINLESS STEEL TE-SCREW 8X16
270311	NIPPLE 3/4"-1/2"
280121	ELL FOR VAACUM BREAKER
290410	NIPPLE 1/2"
290422	NIPPLE 3/8" GAS X RINSE
290603	CHECK VALVE 3/4"-4022.27
290609	CHECK VALVE 3/4"
300508	LOCK NUT 3/4"
301001	NIPPLE FE-ZN 3/4"
330342	BOILER C95-C155-C165
330725	STANDARD BRACKET F.SOLEN.VALV
330756	SOLENOID VALVE BRACKET BT
331914	PLATE FOR RINSE BOOSTER PUMP F
450102	CLAMP FE ZN 11-17 H=9
450103	CLAMP FE ZN. 13-20 H=9
450115	ELASTIC CLAMP D.8,3/7,8
460502	GASKET 30X21X2
510403	CONNECT.HOSE 90Ø1/2"X12
620120	RINSE AID INJECTOR
620209	INLET WATER FILTER
620243	VACUUM BREAKER (WITHOUT KIT)
630969	COIL S4216 220/50HZ

POMPA LAVAGGIO - POMPE LAVAGE  
WASH PUMP - WASCHPUMP - BOMBA LAVADO

100716	220 - 240 - 380 - 415/3	50 Hz
100724	220 - 240 - 380 - 415/3	60 Hz
100726	220 - 240/1	50 Hz
100725	220 - 240/1	60 Hz

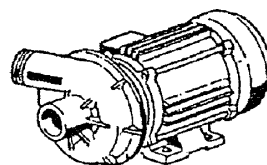

HP 2 - Kw 1,5 (1204)

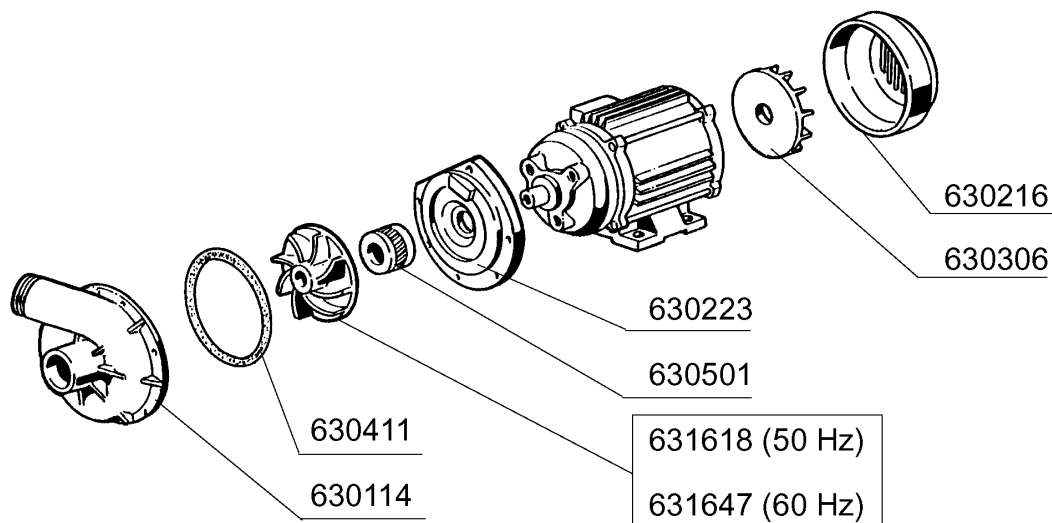

POMPA SOLLEVAMENTO CAPOT - POMPE RELEVAGE CAPOTE  
HOOD LIFTING PUMP - HAUBENÖFFNUNGSPUMPE - BOMBA LEVANTAMIENTOCAPOTE  
HP 0,45 - Kw 0,33

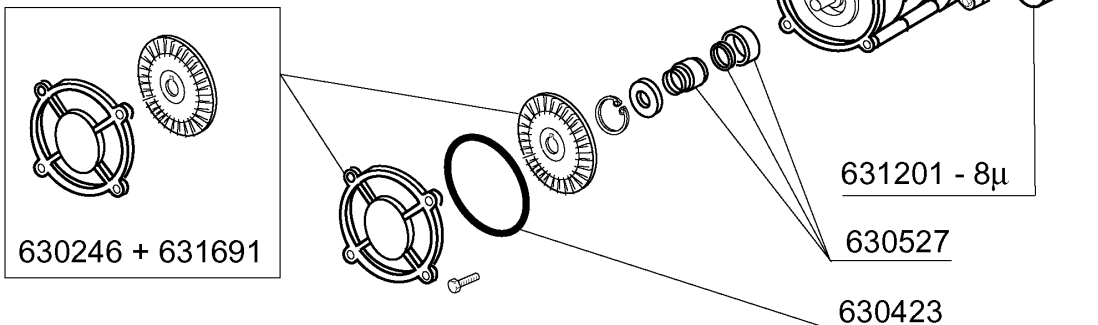
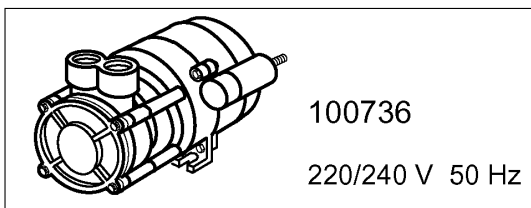

**9 - Pump**

<b>CODE</b>	<b>DESCRIPTION</b>
100716	PUMP 2HP 220/3-415/50-1204
100724	PUMP 2HP 230/400 60HZ 1204
100725	PUMP 2HP 230/1 60HZ 1204
100726	PUMP 2HP 220-240/1 50HZ 1204
100736	PUMP HP 0,5 220/240-50HZ
630114	VOLUTE FI HP2-2,7-3-3,2
630216	FAN HOUSING FIR HP 2-3
630223	BACK PLATE PUMP HP2-3-3,2
630246	COVER FOR PUMP 100736
630306	PUMP FAN IMPELLOR FI HP.2-3
630411	O-RING PUMP FI HP 2-2,7
630423	GASKET FOR PUMP 100736
630501	SEAL FOR PUMP HP 2-3-3,2
630527	SEAL FOR RINSE BOOSTER PUMP
631201	CONDENSER 8MF 450V
631618	IMPELLER PUMP F HP2-D.116,5
631647	IMPELLER D.100-60HZ-1204/5
631691	IMPELLER FOR PUMP 100736



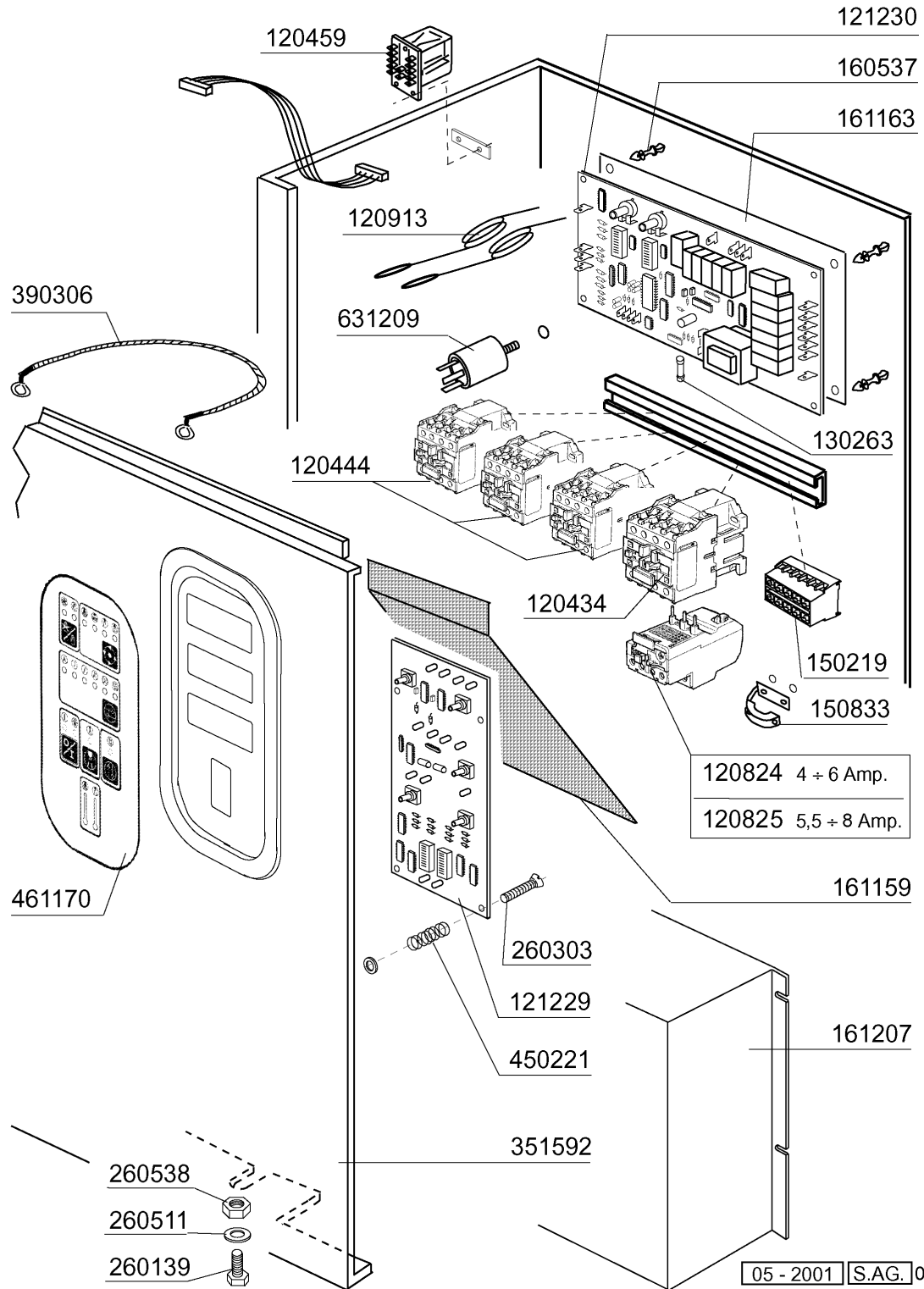

## 10 - Control Box

CODE	DESCRIPTION
120434	CONTACTOR 9A 220V 50HZ
120444	CONTACTOR 9A 220V 50HZ
120459	AUXIL.RELE 16A 220V
120824	OVERLOAD RELAY 4/6 A
120825	OVERLOAD RELAY 5,5/8 A
120913	PROBE FOR FC+C PCB
121229	ELECTRONIC CONTROL PANEL "C"
121230	ELECTRONIC PANEL C166
130263	FUSE 5X20 T400MA
150219	TERMINAL BLOCK 5P MMQ165VD26
150833	CABLE HOLDER BC/BR
160537	ELECTRONIC CARD SPACER
161159	PROTECT.COMMANDS SWITCHBOARD
161163	PROTECT.COMMANDS SWITCHBOARD C
161207	CONTROL BOX COVER FOR C95-155
260139	SCREW TE 5X16
260303	SCREW TSP 3X10
260511	GROWER WASHER D.5
260538	WASHER 18X6X1,5 ST/ST
351592	FRONT PANEL C166
390306	CABLE
450221	SPRING FOR ELECTRONIC TIMER
461170	PLATE C166
631209	ANTI-NOISE FILTER

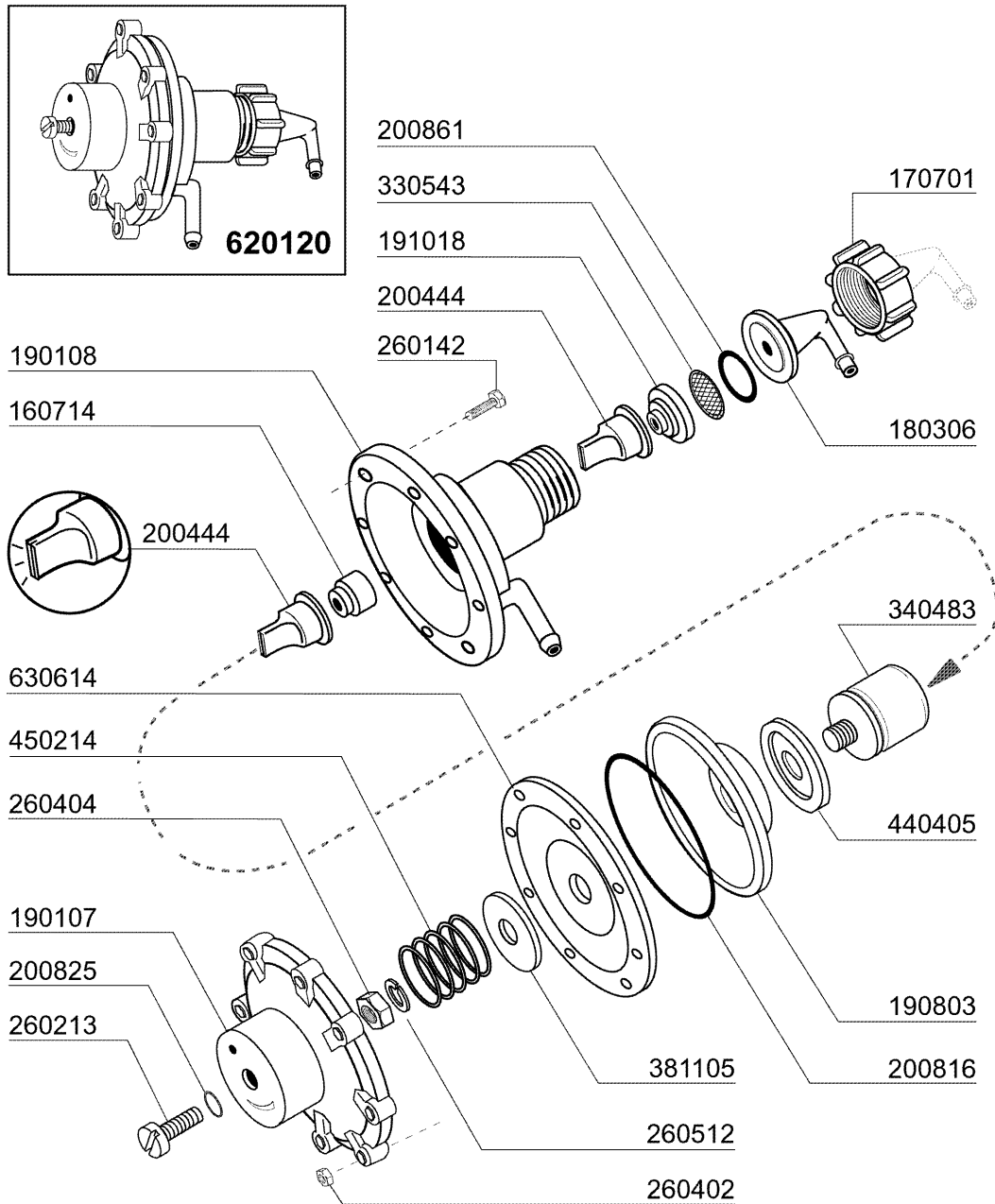

02 - 2004 | S. AG.

11 - Rinse aid injector

CODE	DESCRIPTION
160714	PLUG FOR RINSE AID INJECTOR MO
170701	LOCK NUT 1/2" F.INJECTOR
180306	NIPPLE F.RINSE AID INJECTOR
190107	COVER FOR RINSE AID DISPENSER
190108	VOLUTE FOR RINSE AID DISPENSER
190803	GASKET SUPPORT RING F.INJECT
191018	FILTER SUPPORT RINSE AID INJEC
200444	SUCTION VALVE RINSE INJECTOR
200816	O-RING 2,5X59,2X64,2 RINSE INJ
200825	O-RING 3X5X11 RINSE INJECTOR
200861	O-RING 14X18X2
260142	SCREW TE 4X16
260213	SCREW TCP 5X25
260402	STAINLESS STEEL NUT D4 UNI 55
260404	STAINLESS STEEL NUTS D6 UNI 55
260512	ST/ST GROWER WASHER D6
330543	FILTER RINSE AID INJECTOR D.17
340483	PISTON FOR RINSE AID DISPENSER
381105	DIAPHRAGME DISC
440405	GASKET FOR RINSE AID INJ.
450214	SPRING RINSE AID INJECTOR
620120	RINSE AID INJECTOR
630614	DIAPHRAGM RINSE INJECTOR

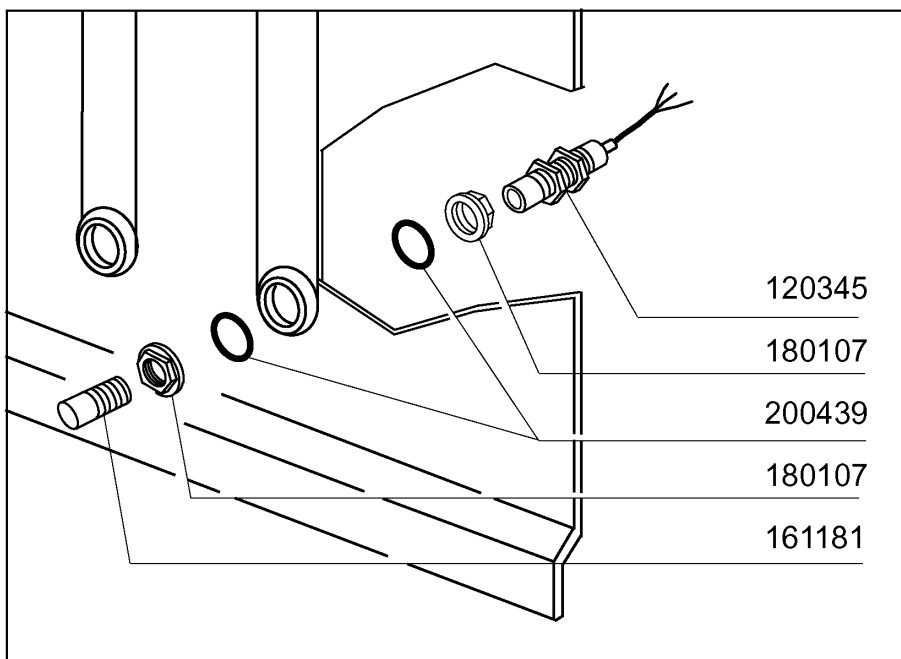
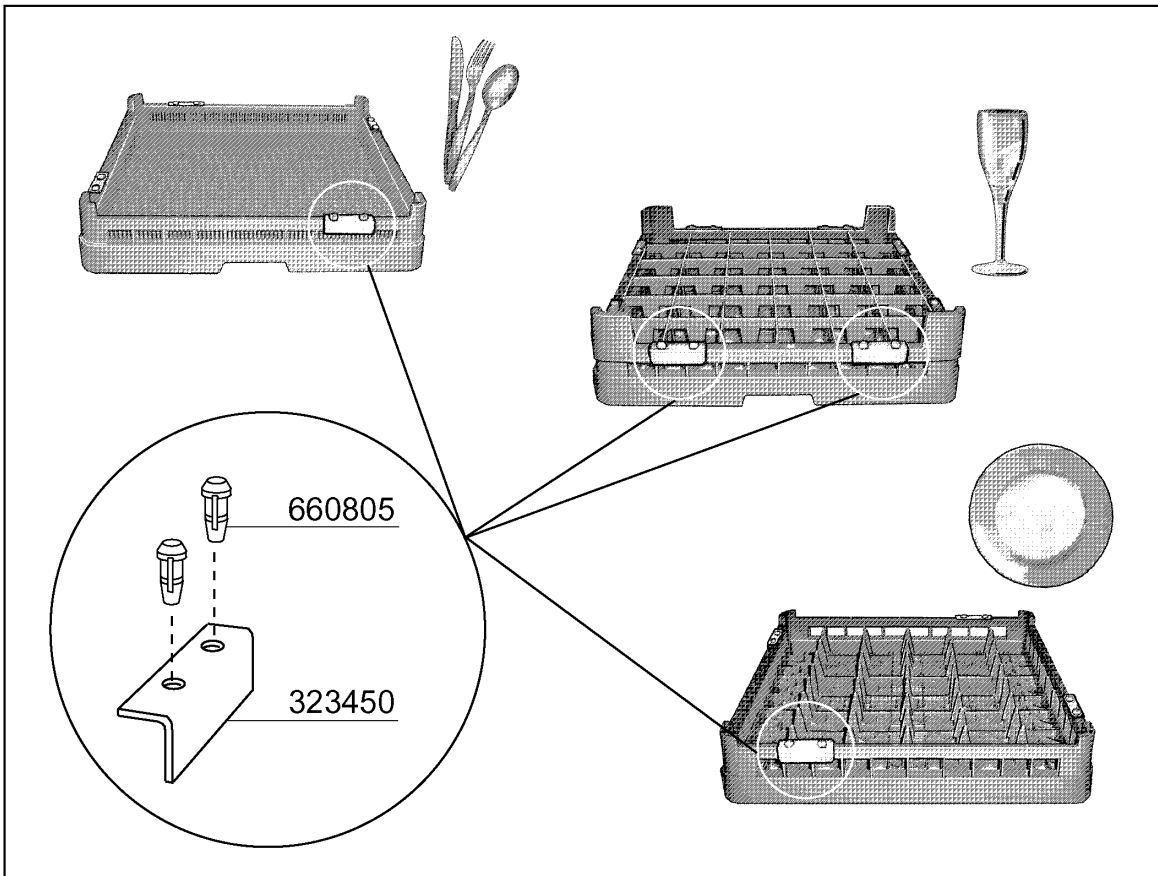

## 12 - Rack recognition system

<b>CODE</b>	<b>DESCRIPTION</b>
120345	PROXIMITY FOR TRAY WASHER
161181	HOUSING
180107	LOCK NUT 1"1/4 B31 F.DRAIN PIP
200439	GASKET NEOPR.D.54X42X2,5 B31
323450	BRACKET
660805	RACK FIXING PEGS (NYLON)